

Solent Engineering

01243 512113 /07876303239

Email solentengineeringsales@btconnect.com

Web solentengineering.co.uk

SCS02

HIGH SPEED NET CLEARER

LIGHT WEIGHT NET STACKER



SOLENT SCS02 IS DEVELOPED FOR HIGH SPEED LARGE VOLUME NET CLEARING AND STACKING YET IN A COMPACT LIGHTWEIGHT FORM, FEATURES INCLUDE VARIABLE ANGLE SPREADER BOW, ADJUSTABLE FAIR LEAD ENTRANCE, COMES COMPLETE WITH VARIABLE CONTROL VALVE AND PIPING.

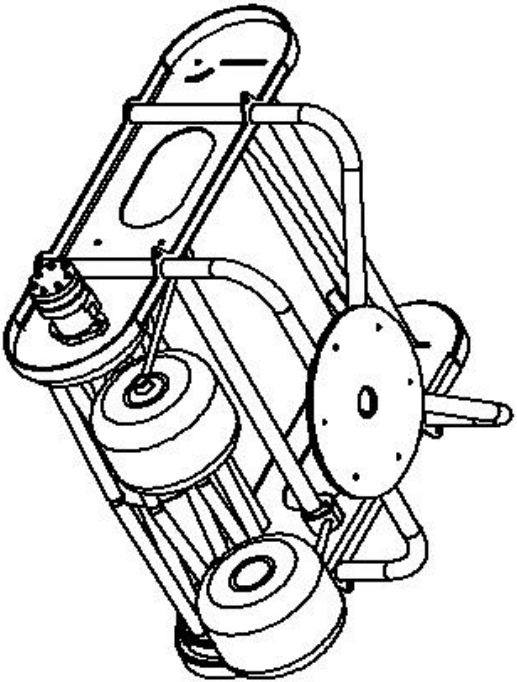
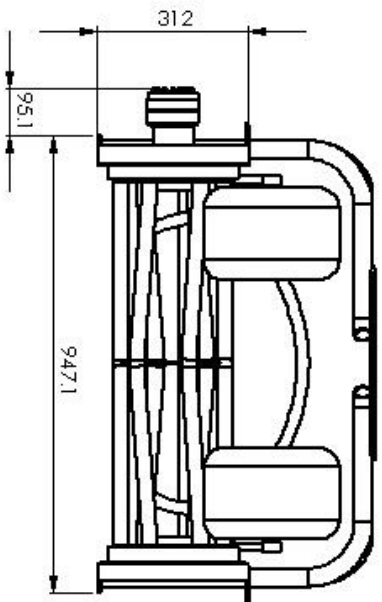
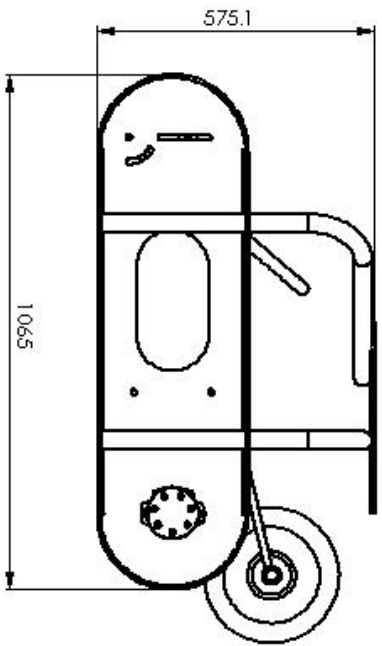

- SPECIFICATIONS**
- WEIGHT 35KG
 - REQUIRED OIL FLOW 13LPM
 - REQUIRED OIL PRESSURE 140BAR
 - AVERAGE FLEETING SPEED 100 M/PM
 - MAX FLEETING SPEED 180M/PM

UNITS: COMPANY SPECIFIC		TRADE		DIMS AND BENCH MARK POINTS		DWG NO	
DESCRIPTION	UNIT	DESCRIPTION	UNIT	DESCRIPTION	UNIT	DESCRIPTION	UNIT
DRIVE	DIMENSION	SEPARATOR	DATE				
CHAS							
W/O							
D.A.							
				MATERIAL:		solenteng@solenteng.co.uk	
				VEHICLE:		Tel: +44(0)10 1208877 / 01240 012113	
						A3	

Solent Engineering Services

SCS02