

CONVEYOR GILL

NET HAULER

SCH02



STARBOARD OR PORT FISHING SIDES

COMES COMPLETE WITH PEDESTAL LEG, CLAMP, SWIVEL FOOT, VARIABLE CONTROL VALVE WITH RELIEF VALVE, AND SUPPLIED PIPED READY FOR USE

250kg PULL STANDARD 500KG OPTIONAL

DOUBLE SPRUNG BALLS

EXTERNAL BELT TENSIONERS

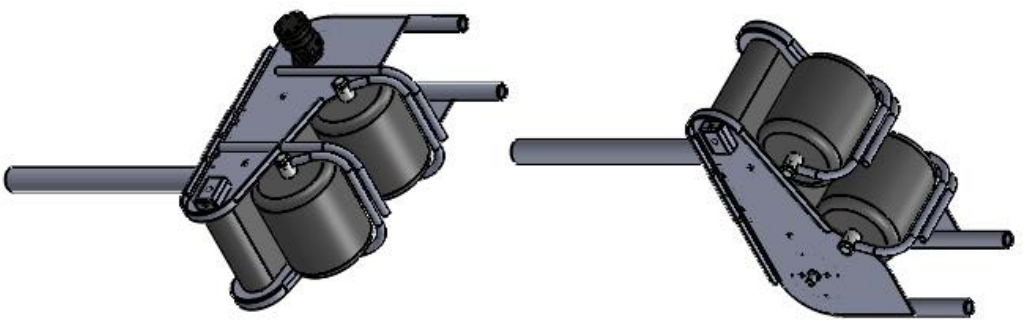
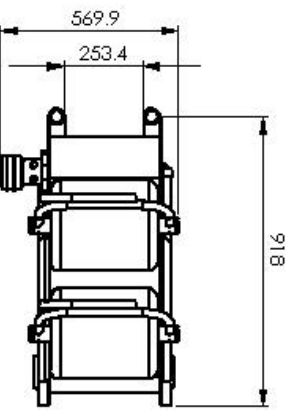
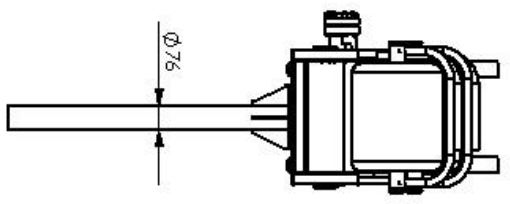
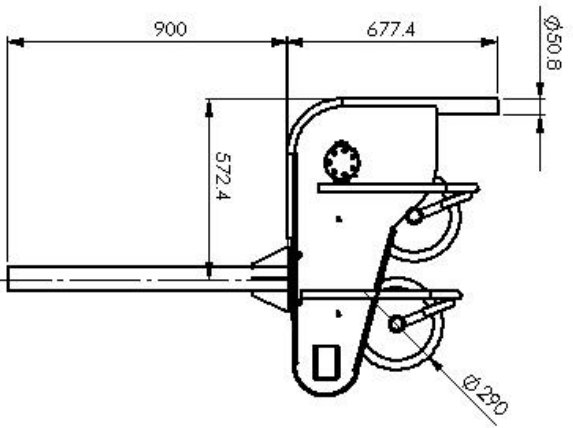

PERFORMANCE SPECIFICATION

AVERAGE HAULING SPEED 70 MPM
 MAX HAULING SPEED 130MPM
 NET PULL 250 KG
 WEIGHT OF NET HAULER 50KG
 OIL FLOW 10-16LPM
 MAX PRESSURE 200BAR

DRIVER'S OPERATOR PROTECTIVE DEVICES (SEAT BELT SAFETY)	TRIP	OTHER AIR FILTERS
DRIVER'S OPERATOR PROTECTIVE DEVICES (SEAT BELT SAFETY)	TRIP	OTHER AIR FILTERS
DRIVER'S OPERATOR PROTECTIVE DEVICES (SEAT BELT SAFETY)	TRIP	OTHER AIR FILTERS
DRIVER'S OPERATOR PROTECTIVE DEVICES (SEAT BELT SAFETY)	TRIP	OTHER AIR FILTERS
DRIVER'S OPERATOR PROTECTIVE DEVICES (SEAT BELT SAFETY)	TRIP	OTHER AIR FILTERS

DRIVER'S OPERATOR PROTECTIVE DEVICES (SEAT BELT SAFETY)	TRIP	OTHER AIR FILTERS
DRIVER'S OPERATOR PROTECTIVE DEVICES (SEAT BELT SAFETY)	TRIP	OTHER AIR FILTERS
DRIVER'S OPERATOR PROTECTIVE DEVICES (SEAT BELT SAFETY)	TRIP	OTHER AIR FILTERS
DRIVER'S OPERATOR PROTECTIVE DEVICES (SEAT BELT SAFETY)	TRIP	OTHER AIR FILTERS
DRIVER'S OPERATOR PROTECTIVE DEVICES (SEAT BELT SAFETY)	TRIP	OTHER AIR FILTERS

DRIVER'S OPERATOR PROTECTIVE DEVICES (SEAT BELT SAFETY)	TRIP	OTHER AIR FILTERS
DRIVER'S OPERATOR PROTECTIVE DEVICES (SEAT BELT SAFETY)	TRIP	OTHER AIR FILTERS
DRIVER'S OPERATOR PROTECTIVE DEVICES (SEAT BELT SAFETY)	TRIP	OTHER AIR FILTERS
DRIVER'S OPERATOR PROTECTIVE DEVICES (SEAT BELT SAFETY)	TRIP	OTHER AIR FILTERS
DRIVER'S OPERATOR PROTECTIVE DEVICES (SEAT BELT SAFETY)	TRIP	OTHER AIR FILTERS

DO NOT SCALE DRAWING

REVISED

Solent Engineering Services

DWG NO

Solent Conveyor Hauler

solentengineering@btconnect.com
 Tel: +447810 123887 / 01243 512113

A3

SHEET 1 OF 1